

THIS DRAWING IS UNPUBLISHED. RELEASED FOR PUBLICATION
 © COPYRIGHT - BY TYCO ELECTRONICS CORPORATION. ALL RIGHTS RESERVED.

LOC DW DIST -

REVISIONS					
P	LTR	DESCRIPTION	DATE	DWN	APVD
	A	REVISED ECR-06-007034	27APR06	JL	WK
	A1	REVISED ECR-07-006694	22MAR07	JL	WK

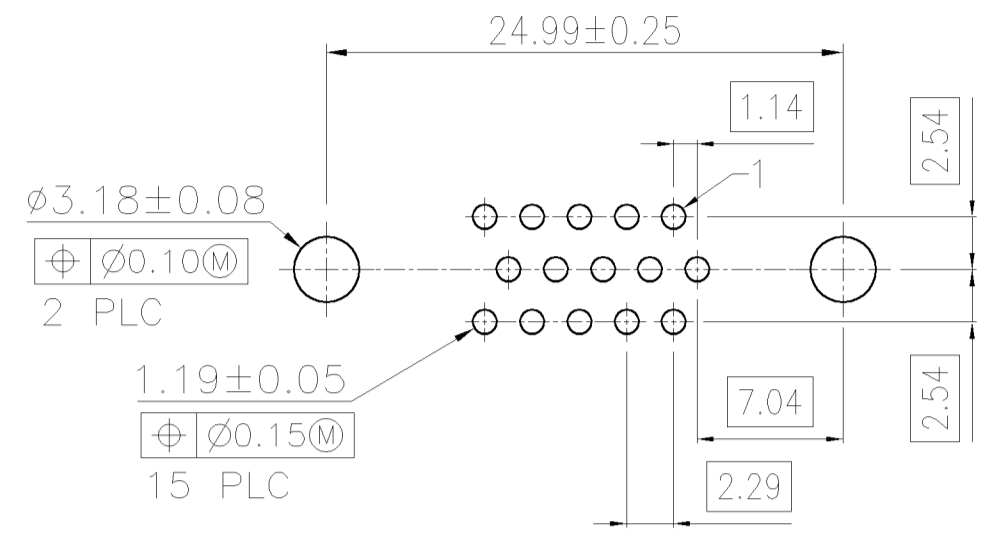
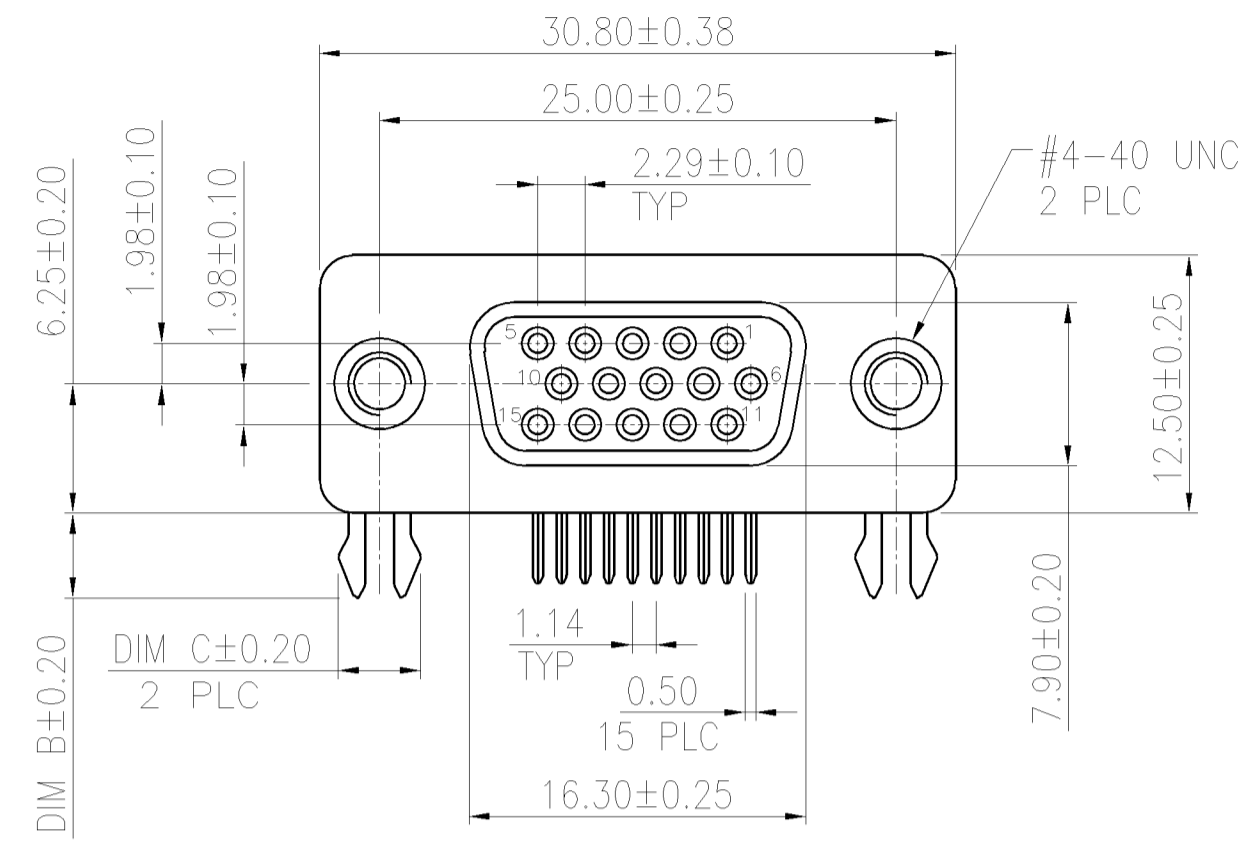

RECOMMENDED P.C. BOARD LAYOUT

- NOTES:
- MATERIAL:
 - HOUSING: THERMOPLASTIC(NY9T), UL 94V-0 RATED,BLACK
 - CONTACTS: PHOPHOR BRONZE
 - SHELL: SPCC
 - BOARDLOCKS: BRASS
 - RIVET: BRASS
 - SCREWLOCK: BRASS
 - FINISH:
 - CONTACT:
 - GOLD PLATING ON CONTACT AREA. (SEE TABLE)
 - 2.54um[100u"] MIN. MATTE TIN PLATING ON SOLDER TAIL AREA,
 - 1.27um[50u"] MIN. NICKEL UNDERPLATING OVERALL,
 - BOARDLOCK:
 - 2.54um[100u"] MIN MATTE TIN PLATING
 - 1.27um[50u"] MIN NICKEL UNDERPLATING OVERALL,
 - SHELL: NICKEL PLATED
 - RIVET: NICKEL PLATING 0.76um[30u"] OVERALL.
 - FIXED SCREWLOCK: NICKEL PLATING 0.76um[30u"] MEETS 6 IN-LB TORQUE.
 - RECOMMENDED PCB THICKNESS: 1.6 mm
 - REFLOW SOLDER CAPABLE TO 260°C PER TYCO SPEC. 109-201, CONDITION B.
 - NET WEIGHT: 10.24 g/pcs. (WITH SCREWLOCK) 8.24 g/pcs. (W/O SCREWLOCK)
- ⚠ BOARDLOCK INSERTION FORCE: 1.5±0.5 Kgf [15±5 N]. FOR 5-1734530-3 & 6-1734530-3 ONLY.

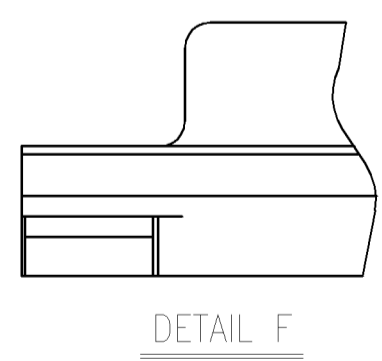
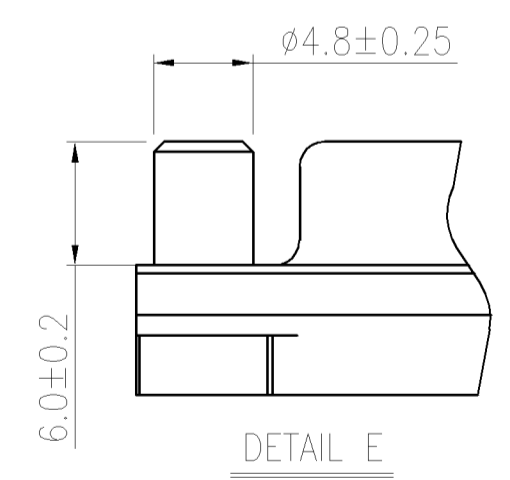
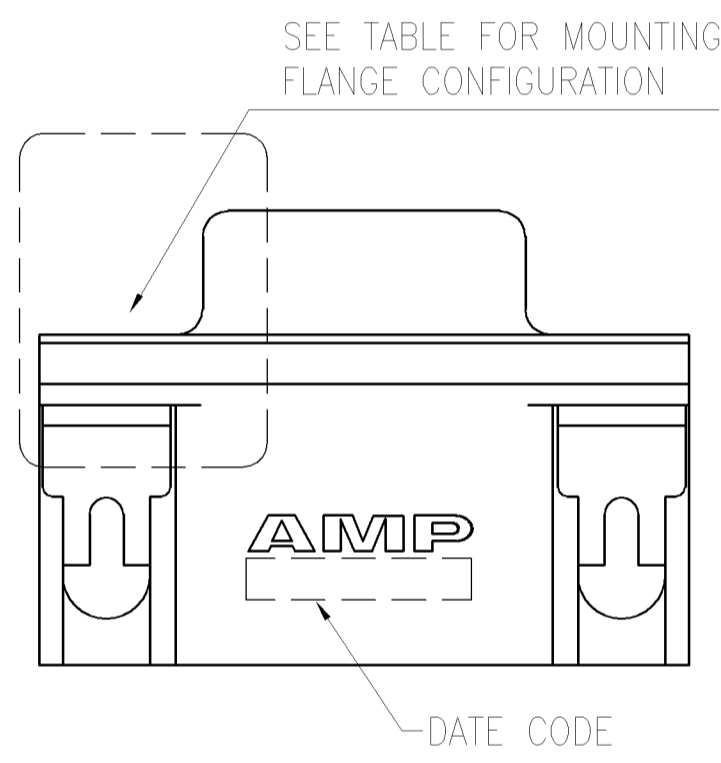
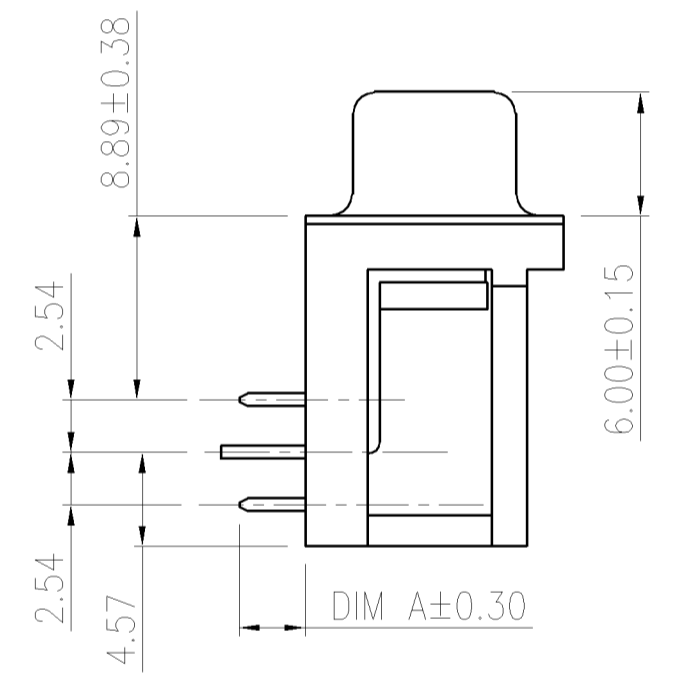
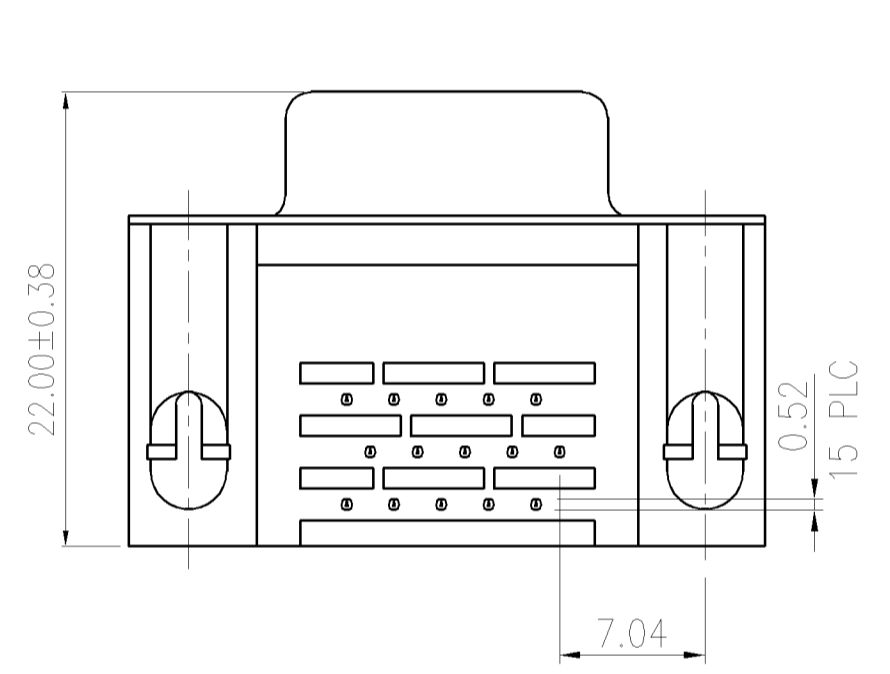

TAPE&REEL	DETAIL	W/	3.78⚠	3.20⚠	3.18	30 μ"	6-1734530-3
TAPE&REEL	DETAIL E	W/	3.78⚠	3.20⚠	3.18	30 μ"	5-1734530-3
TRAY	DETAIL F	W/O	4.00	4.10	3.18	30 μ"	3-1734530-3
TUBE	DETAIL F	W/	4.00	4.10	3.18	30 μ"	2-1734530-3
TUBE	DETAIL F	W/	4.00	4.10	3.18	15 μ"	2-1734530-2
TUBE	DETAIL F	W/	4.00	4.10	3.18	G/F	2-1734530-1
TRAY	DETAIL F	W/	4.00	4.10	2.16	30 μ"	1-1734530-6
TRAY	DETAIL F	W/	4.00	4.10	2.16	15 μ"	1-1734530-5
TRAY	DETAIL F	W/	4.00	4.10	2.16	G/F	1-1734530-4
TRAY	DETAIL F	W/	4.00	4.10	3.18	30 μ"	1-1734530-3
TRAY	DETAIL F	W/	4.00	4.10	3.18	15 μ"	1-1734530-2
TRAY	DETAIL F	W/	4.00	4.10	3.18	G/F	1-1734530-1
TRAY	DETAIL E	W/	4.00	4.10	2.16	30 μ"	1734530-6
TRAY	DETAIL E	W/	4.00	4.10	2.16	15 μ"	1734530-5
TRAY	DETAIL E	W/	4.00	4.10	2.16	G/F	1734530-4
TRAY	DETAIL E	W/	4.00	4.10	3.18	30 μ"	1734530-3
TRAY	DETAIL E	W/	4.00	4.10	3.18	15 μ"	1734530-2
TRAY	DETAIL E	W/	4.00	4.10	3.18	G/F	1734530-1
PACKAGING	MOUNTING FLANGE CONFIGURATION	BOARDLOCK OPTION	DIM C	DIM B	DIM A	Gold Finish	PART NO.

THIS DRAWING IS A CONTROLLED DOCUMENT.		DWN J. LEE 22MAR2007	Tyco Holdings (Bermuda) VII Ltd. Taiwan Branch			
DIMENSIONS: MM		CHK S. HOU 22MAR2007				
TOLERANCES UNLESS OTHERWISE SPECIFIED:		APVD W.J. KE 22MAR2007	NAME			
0 PLC ± - 1 PLC ± 0.38 2 PLC ± 0.25 3 PLC ± 0.15 4 PLC ± - ANGLES ± -		PRODUCT SPEC 108-57541	RECEPTACLE ASSY, SIZE 1, 15 POSITION, RIGHT ANGLE, THROUGH HOLE			
MATERIAL SEE NOTE		QUALIFICATION TEST REPORT 501-57623	SIZE	CAGE CODE	DRAWING NO	RESTRICTED TO
FINISH SEE NOTE		WEIGHT SEE NOTE	A3	00779	C-1734530	-
CUSTOMER DRAWING			SCALE -	SHEET 1 OF 4	REV A1	

THIS DRAWING IS UNPUBLISHED. RELEASED FOR PUBLICATION
 © COPYRIGHT BY TYCO ELECTRONICS CORPORATION. ALL RIGHTS RESERVED.

LOC	DIST	REVISIONS			
P	LTR	DESCRIPTION	DATE	DWN	APVD
DW	—	SEE SHEET 1.			

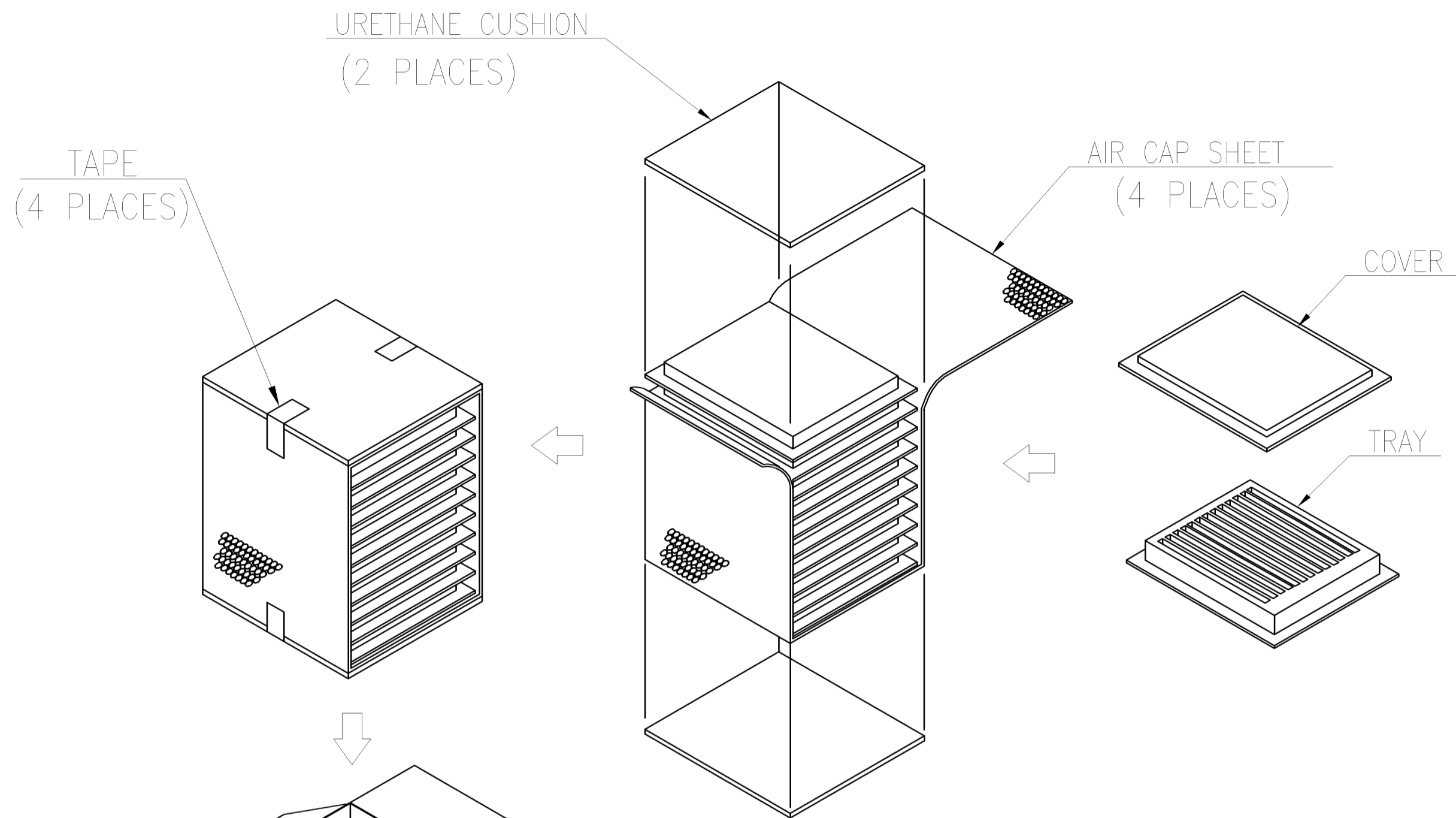

- NOTES:
- MATERIAL:
 - 1.1 TRAY: PVC
 - 1.2 SHIPPING CARTON: CORRUGATED FIBERBOARD
 - DIMENSION:
 - 2.1 TRAY: L=320, W=230, H=18.9
 - 2.2 SHIPPING CARTON: L=361, W=245, H=272
 - QUANTITY:
 - 3.1 PRIMARY PACKING: 100 PCS/TRAY
 - 3.2 SECONDARY PACKING: 10 TRAY/CARTON(1000PCS)
 - CARTON WEIGHT:
 - 4.1 NET WEIGHT: 10.24 Kg (W/SCREWLOCK)
 - 4.2 GROSS WEIGHT: 11.24 Kg (W/SCREWLOCK)
 - 4.3 NET WEIGHT: 8.24 Kg (W/O SCREWLOCK)
 - 4.4 GROSS WEIGHT: 9.24 Kg (W/O SCREWLOCK)

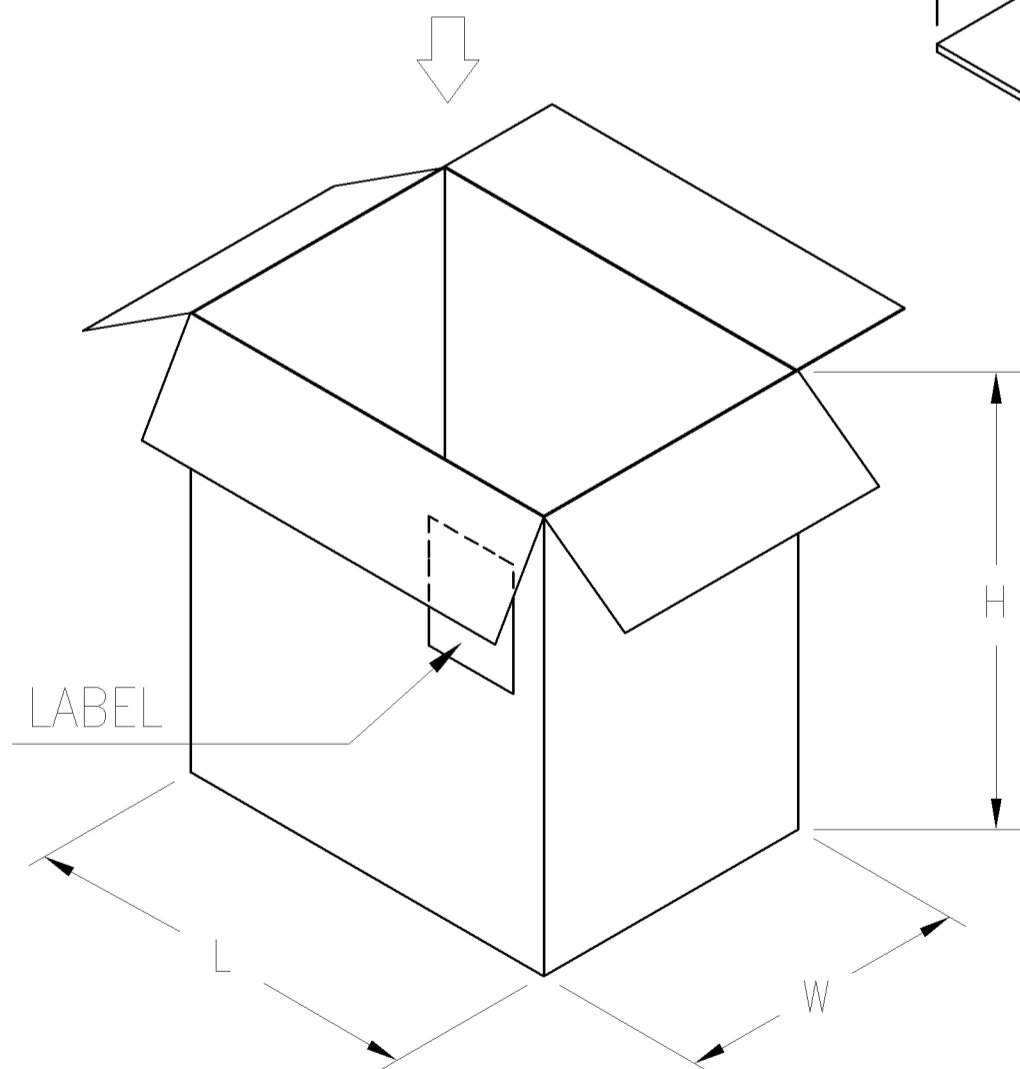

THIS DRAWING IS A CONTROLLED DOCUMENT.		DWN J. LEE 22MAR2007	tyco Tyco Holdings (Bermuda)	
		CHK S. HOU 22MAR2007	Electronics VII Ltd. Taiwan Branch	
		APVD W.J. KE 22MAR2007	NAME RECEPTACLE ASSY, SIZE 1, 15 POSITION, RIGHT ANGLE, THROUGH HOLE	
DIMENSIONS: MM		TOLERANCES UNLESS OTHERWISE SPECIFIED:		PRODUCT SPEC
		0 PLC ± -		APPLICATION SPEC
		1 PLC ± -		WEIGHT
		2 PLC ± -		SIZE
		3 PLC ± -		CAGE CODE
		4 PLC ± -		DRAWING NO
		ANGLES ± -		RESTRICTED TO
MATERIAL		FINISH		A300779
				C=1734530
				CUSTOMER DRAWING
				SCALE —
				SHEET 2 OF 4
				REV A1

THIS DRAWING IS UNPUBLISHED. RELEASED FOR PUBLICATION
 © COPYRIGHT BY TYCO ELECTRONICS CORPORATION. ALL RIGHTS RESERVED.

LOC	DIST	REVISIONS					
DW	—	P	LTR	DESCRIPTION	DATE	DWN	APVD
				SEE SHEET 1.			

INNER BOX

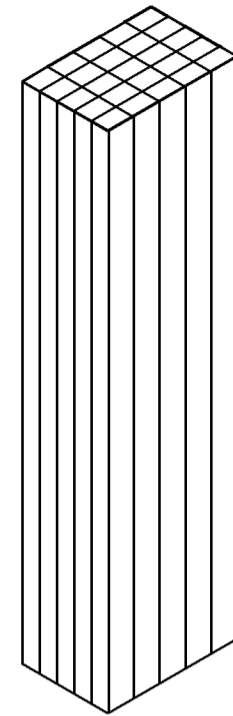
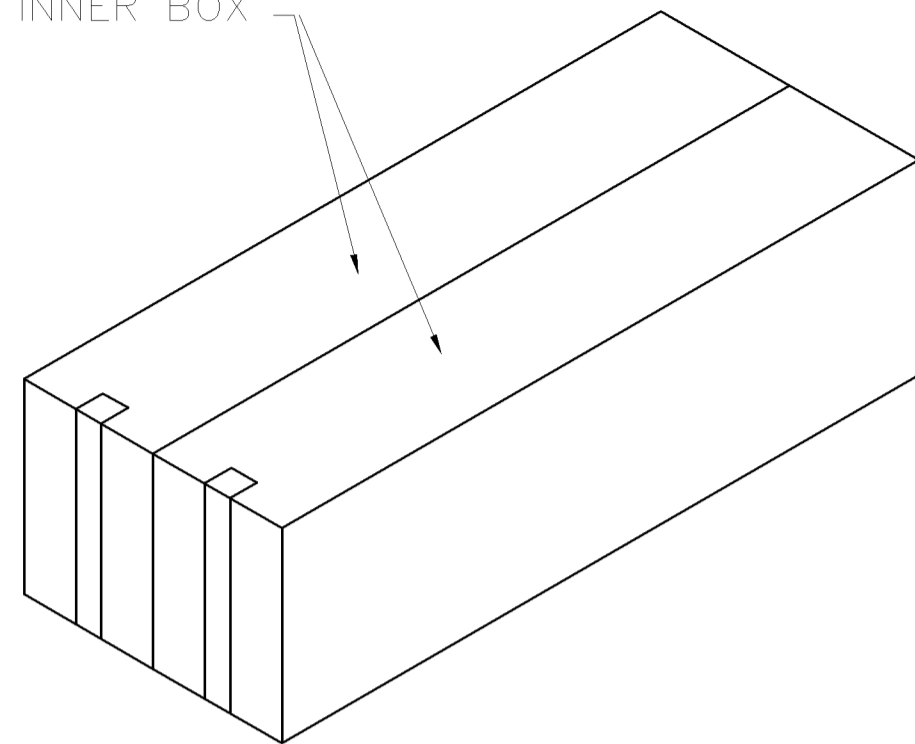

TUBE

NOTES:

1. MATERIAL:
 - 1.1 TUBE: PVC
 - 1.2 SHIPPING CARTON: CORRUGATED FIBERBOARD
2. DIMENSION:
 - 2.1 TUBE: L=560, W=17.8, H=27.4
 - 2.2 SHIPPING CARTON: L=600, W=245, H=195
3. QUANTITY:
 - 3.1 PRIMARY PACKING: 17 PCS/TUBE
 - 3.2 SECONDARY PACKING: 25 TUBE/BOX
 - 3.3 THIRD PACKING: 2 BOX/CARTON(850PCS)
4. CARTON WEIGHT:
 - 4.1 NET WEIGHT: 8.7 Kg (W/O SCREWLOCK)
 - 4.2 GROSS WEIGHT: 9.7 Kg (W/O SCREWLOCK)

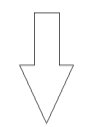
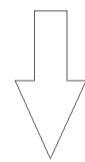

CARTON

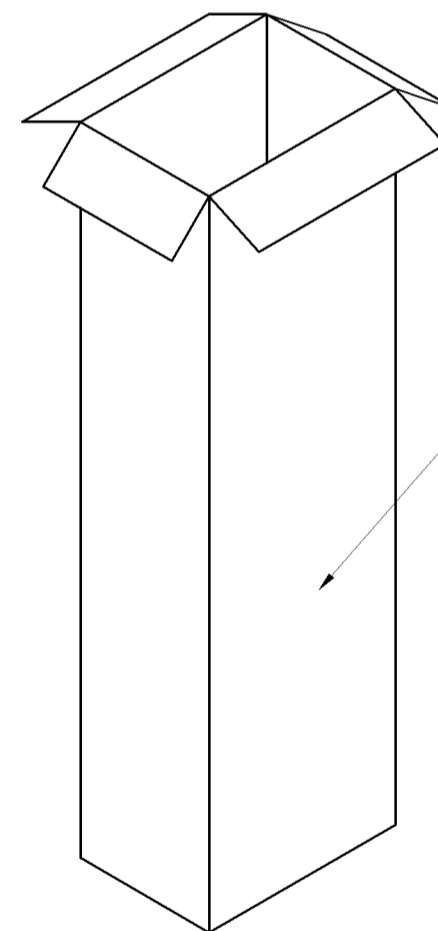
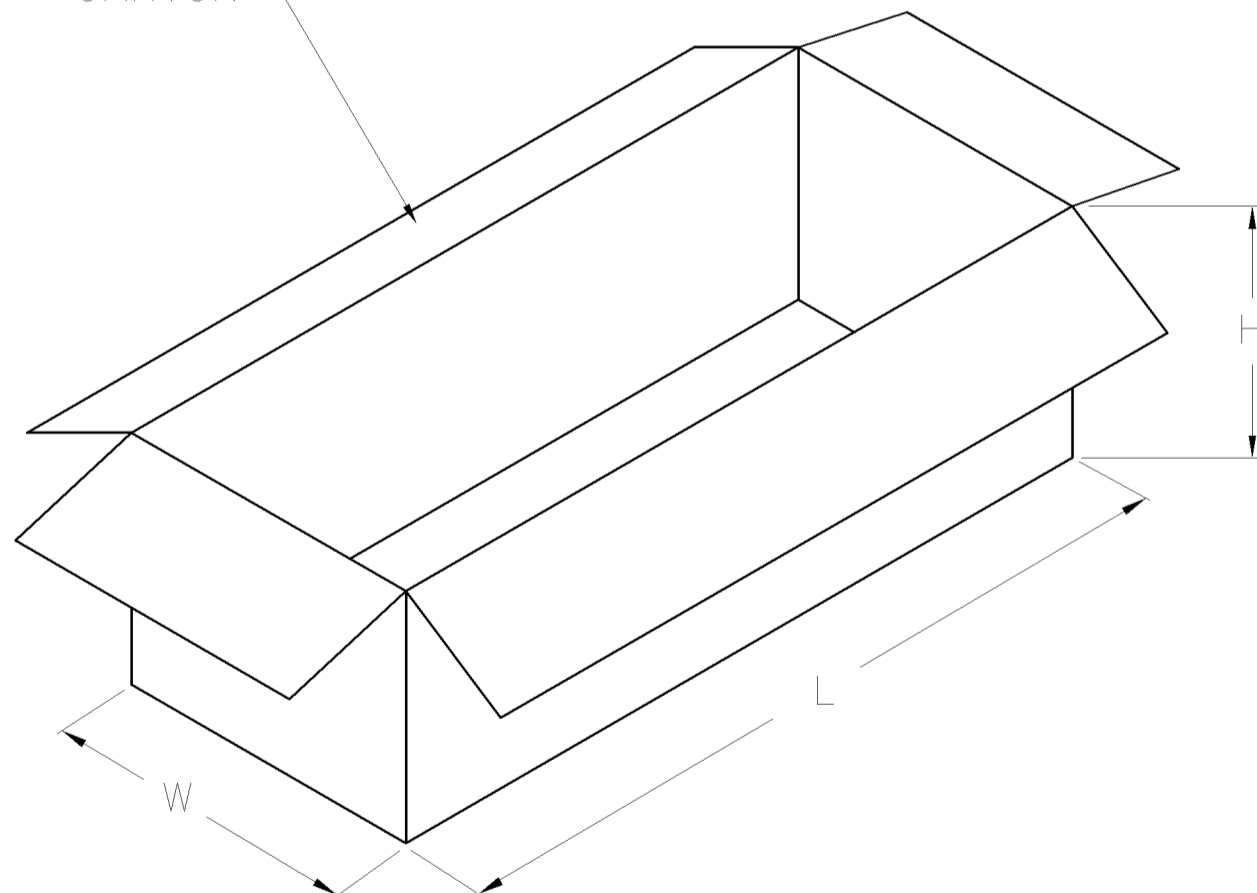

INNER BOX

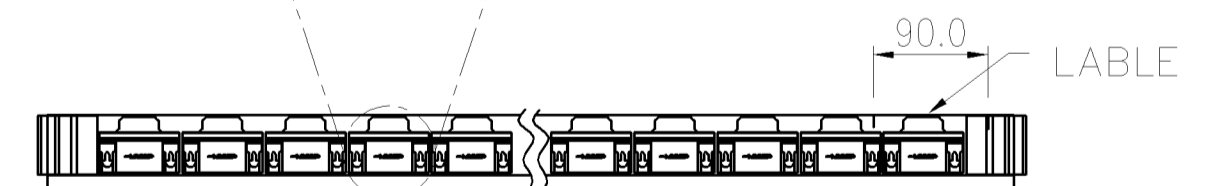
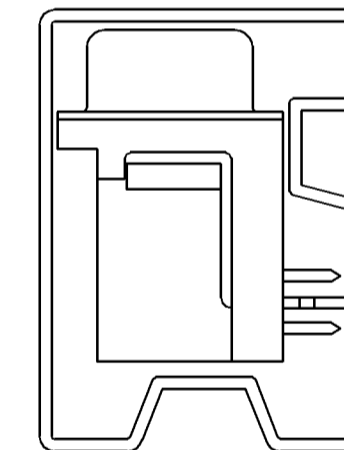
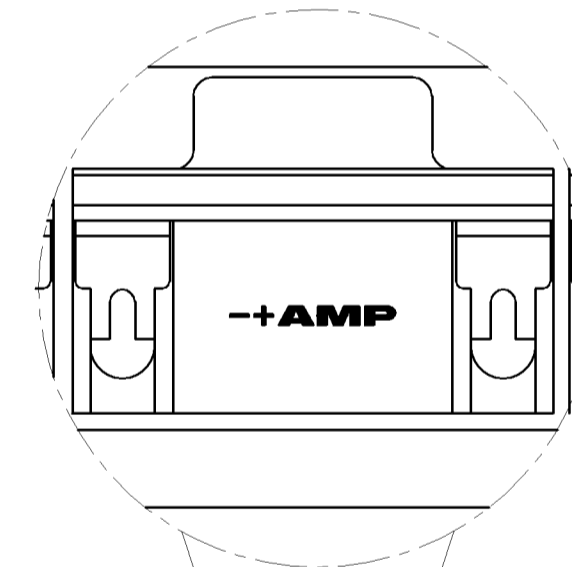

THIS DRAWING IS A CONTROLLED DOCUMENT.		DWN J. LEE 22MAR2007	tyco Tyco Holdings (Bermuda)													
DIMENSIONS: MM		CHK S. HOU 22MAR2007	Electronics VII Ltd. Taiwan Branch													
TOLERANCES UNLESS OTHERWISE SPECIFIED:		APVD W.J. KE 22MAR2007	NAME RECEPTACLE ASSY, SIZE 1, 15 POSITION, RIGHT ANGLE, THROUGH HOLE													
<table border="1"> <tr><td>0 PLC</td><td>± -</td></tr> <tr><td>1 PLC</td><td>± -</td></tr> <tr><td>2 PLC</td><td>± -</td></tr> <tr><td>3 PLC</td><td>± -</td></tr> <tr><td>4 PLC</td><td>± -</td></tr> <tr><td>ANGLES</td><td>± -</td></tr> </table>		0 PLC	± -	1 PLC	± -	2 PLC	± -	3 PLC	± -	4 PLC	± -	ANGLES	± -	PRODUCT SPEC —	SIZE A3	CAGE CODE 00779
0 PLC	± -															
1 PLC	± -															
2 PLC	± -															
3 PLC	± -															
4 PLC	± -															
ANGLES	± -															
MATERIAL —		APPLICATION SPEC —	DRAWING NO C-1734530	RESTRICTED TO —												
FINISH —		WEIGHT —	CUSTOMER DRAWING													
		SCALE —	SHEET 3 OF 4	REV A1												

THIS DRAWING IS UNPUBLISHED. RELEASED FOR PUBLICATION
 © COPYRIGHT BY TYCO ELECTRONICS CORPORATION. ALL RIGHTS RESERVED.

LOC DW
 DIST —

REVISIONS				
P	LTR	DESCRIPTION	DATE	APVD
		SEE SHEET 1.		

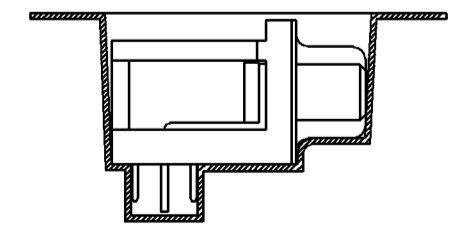
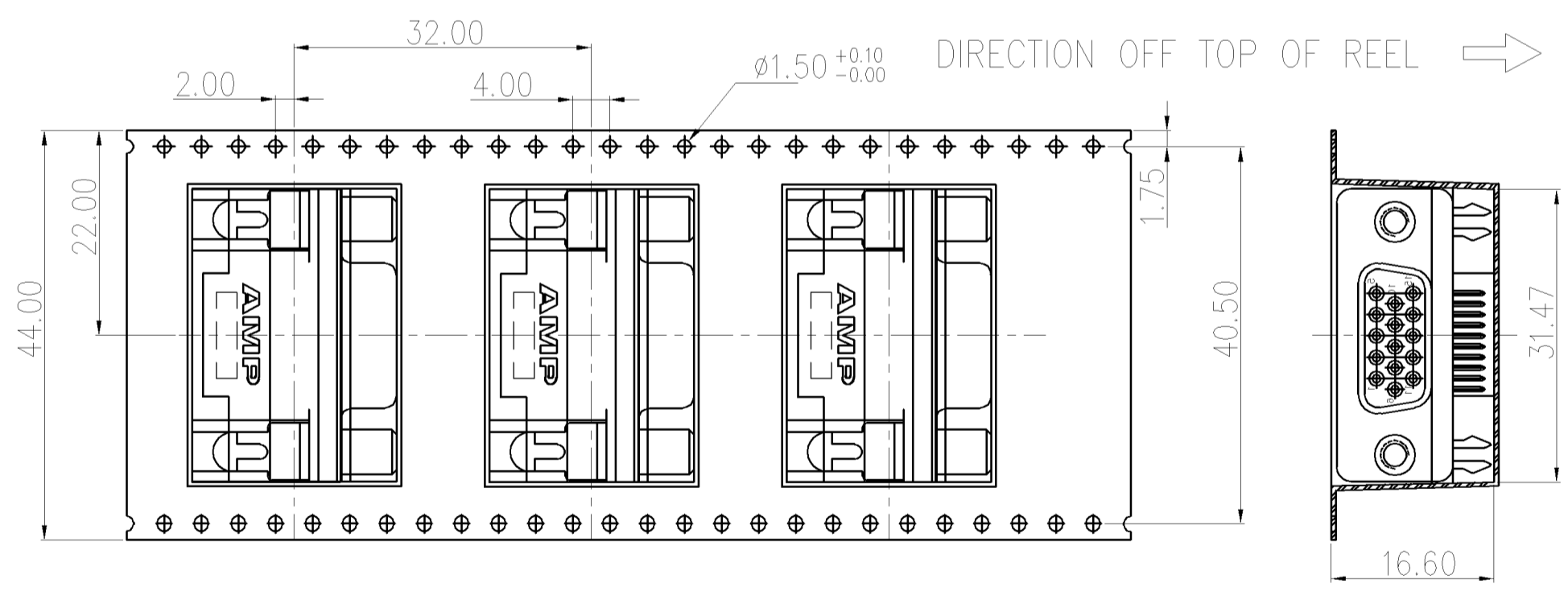
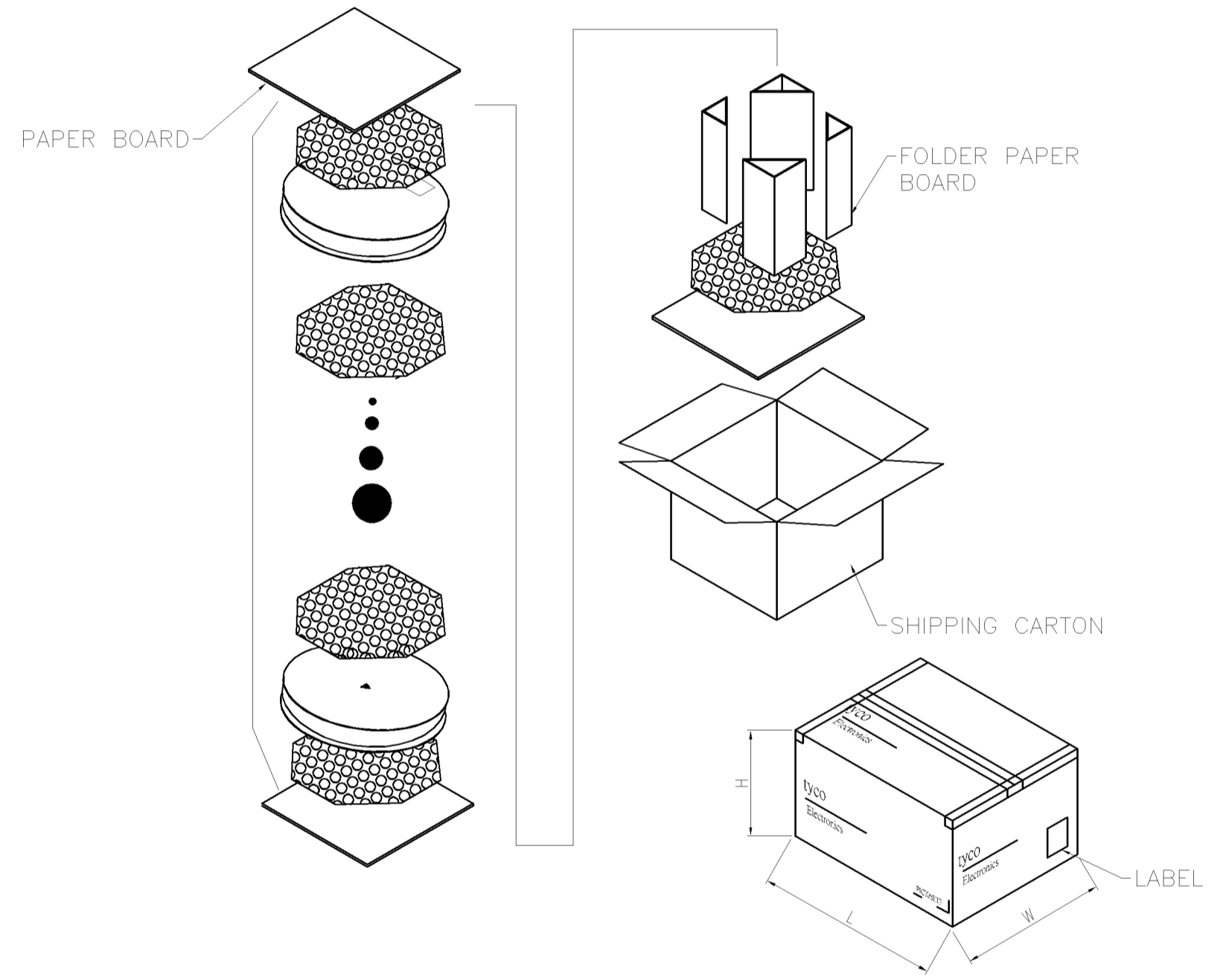
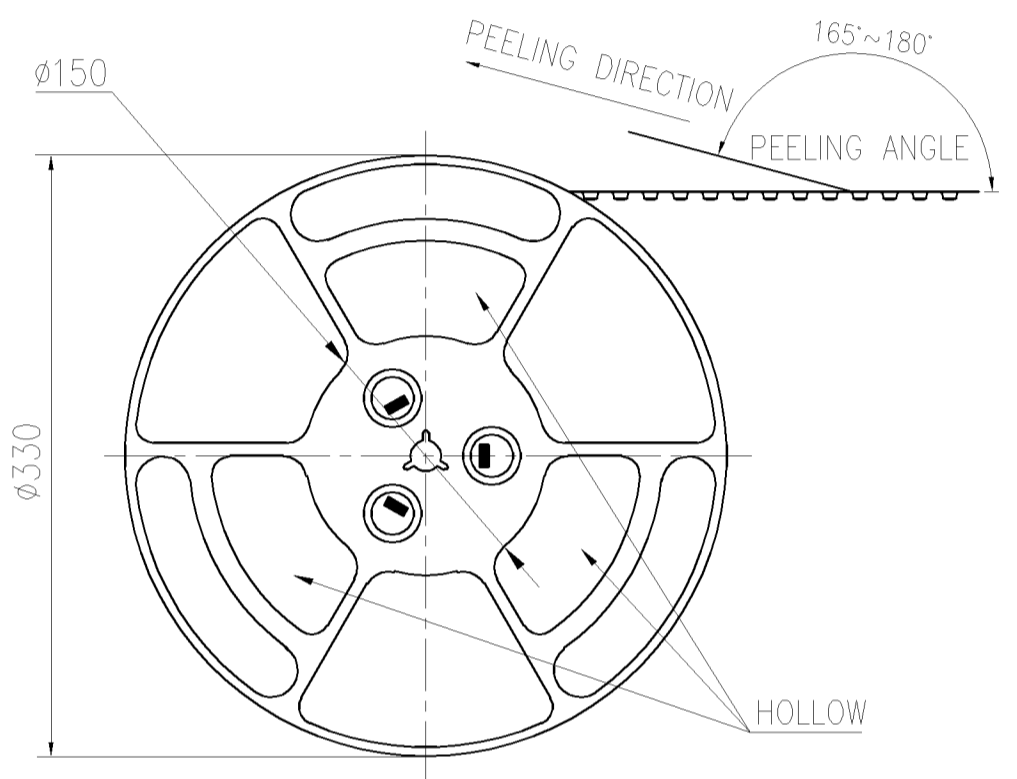
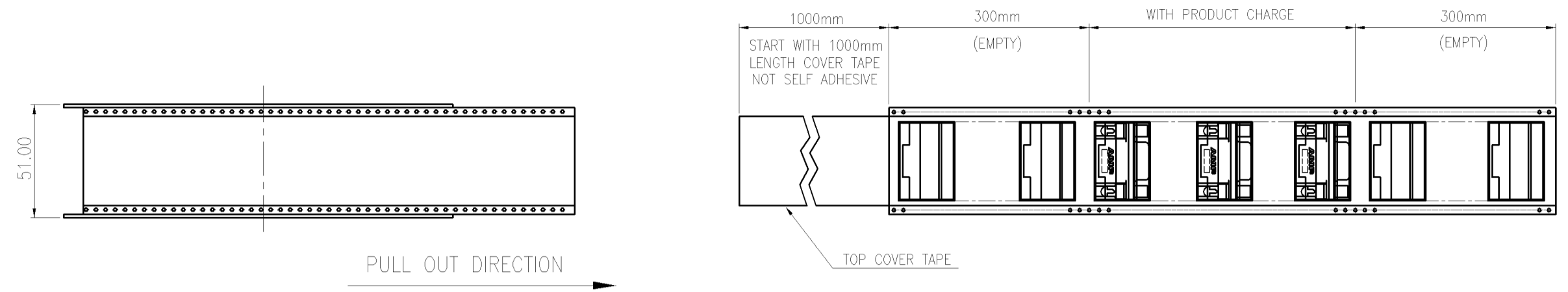

PRODUCT TYPE	PCS/REEL	REEL/CARTON	TOTAL(PCS)	CTN SIZE (CM)	NW(Kg)	GW(Kg)
D-SUB H/D 15P	100	6	600	360X360X350	5.4	5.9

THIS DRAWING IS A CONTROLLED DOCUMENT.

DIMENSIONS: MM	TOLERANCES UNLESS OTHERWISE SPECIFIED:
	0 PLC ± -
	1 PLC ± -
	2 PLC ± -
	3 PLC ± -
	4 PLC ± -
	ANGLES ± -
MATERIAL	FINISH

DWN J. LEE 22MAR2007	 Tyco Holdings (Bermuda) VII Ltd. Taiwan Branch
CHK S. HOU 22MAR2007	
APVD W.J. KE 22MAR2007	
PRODUCT SPEC	NAME RECEPTACLE ASSY, SIZE 1, 15 POSITION, RIGHT ANGLE, THROUGH HOLE
APPLICATION SPEC	SIZE A3
WEIGHT	CAGE CODE 00779
CUSTOMER DRAWING	DRAWING NO C=1734530
	RESTRICTED TO
	SCALE —
	SHEET 4 OF 4
	REV A1